

Write your name here

Surname

Other names

Pearson Edexcel
International
Advanced Level

Centre Number

--	--	--	--	--

Candidate Number

--	--	--	--

Physics

Advanced

Unit 4: Physics on the Move

Thursday 11 June 2015 – Morning

Time: 1 hour 35 minutes

Paper Reference

WPH04/01

You do not need any other materials.

Total Marks

Instructions

- Use **black** ink or ball-point pen.
- **Fill in the boxes** at the top of this page with your name, centre number and candidate number.
- Answer **all** questions.
- Answer the questions in the spaces provided
– *there may be more space than you need.*

Information

- The total mark for this paper is 80.
- The marks for **each** question are shown in brackets
– *use this as a guide as to how much time to spend on each question.*
- Questions labelled with an **asterisk** (*) are ones where the quality of your written communication will be assessed
– *you should take particular care with your spelling, punctuation and grammar, as well as the clarity of expression, on these questions.*
- The list of data, formulae and relationships is printed at the end of this booklet.
- Candidates may use a scientific calculator.

Advice

- Read each question carefully before you start to answer it.
- Keep an eye on the time.
- Try to answer every question.
- Check your answers if you have time at the end.

Turn over ►

P44927A

©2015 Pearson Education Ltd.

1/1/1/1



PEARSON

SECTION A

Answer ALL questions.

For questions 1–10, in Section A, select one answer from A to D and put a cross in the box . If you change your mind, put a line through the box and then mark your new answer with a cross .

1 The number of neutrons in a nucleus of ${}^{197}_{79}\text{Au}$ is

- A 276
- B 197
- C 118
- D 79

(Total for Question 1 = 1 mark)

2 Which of the following is a possible unit for rate of change of momentum?

- A kg m s
- B kg m s⁻¹
- C kg m s⁻²
- D kg m s⁻³

(Total for Question 2 = 1 mark)

3 A positron enters a particle accelerator. As it emerges from the accelerator its mass is measured to be 3.8×10^{-29} kg.

It can be concluded that the positron

- A has become a different particle.
- B is travelling in a circle.
- C is travelling at close to the speed of light.
- D is travelling at a non-relativistic speed.

(Total for Question 3 = 1 mark)



4 Particles of mass m , each carrying a charge q , are travelling with a speed v . They enter a magnetic field of flux density B at right angles to the field. This causes the particles to move in a circular path.

Which of the following changes would decrease the radius of the path of the particles?

- A an increase in m
- B an increase in q
- C a decrease in B
- D an increase in v

(Total for Question 4 = 1 mark)

5 A $500 \mu\text{F}$ capacitor is charged to a potential difference V_1 . A second capacitor of capacitance $50 \mu\text{F}$ is charged to a potential difference V_2 so that the two capacitors store the same amount of energy.

The value of $\left(\frac{V_1}{V_2}\right)^2$ is

- A 100
- B 10
- C 0.1
- D 0.01

(Total for Question 5 = 1 mark)



- 6 A beam of antiprotons enters a uniform magnetic field, causing the beam to change direction as shown in the diagram.

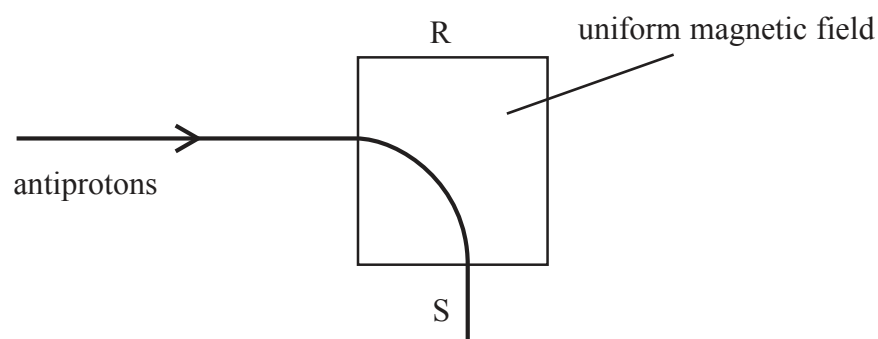

What is the direction of the magnetic field?

- A perpendicularly out of the page
- B perpendicularly into the page
- C towards R
- D towards S

(Total for Question 6 = 1 mark)

- 7 A student suggests that two colliding protons could undergo the interaction

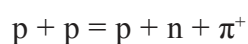

Which of the following statements is true?

- A The interaction is not possible because charge is not conserved.
- B The interaction is not possible because the number of particles is not conserved.
- C The colliding protons must have a very high value of kinetic energy.
- D The resulting particles must have a very high value of kinetic energy.

(Total for Question 7 = 1 mark)



8 The graph shows how the magnetic flux passing through a coil varies with time.

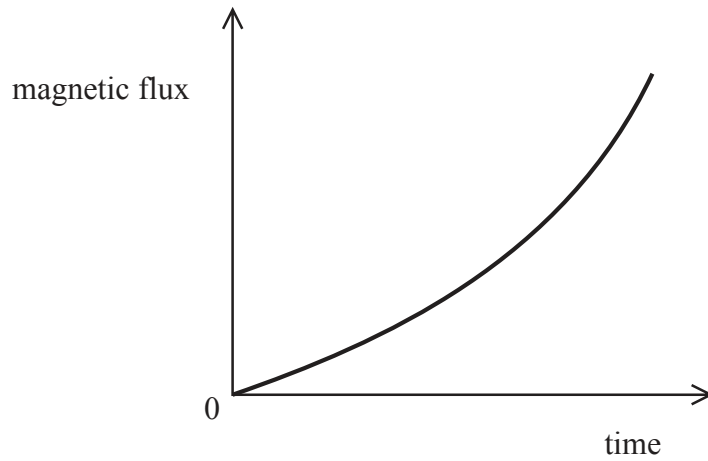

Which of the following graphs could show how the magnitude of the e.m.f. induced in the coil varies with time?

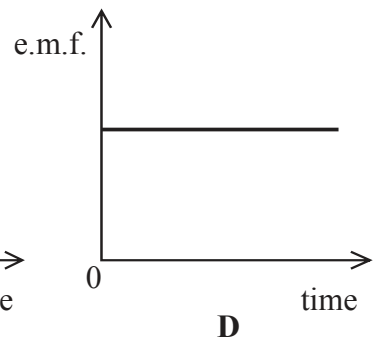
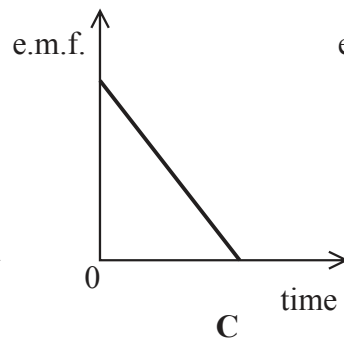
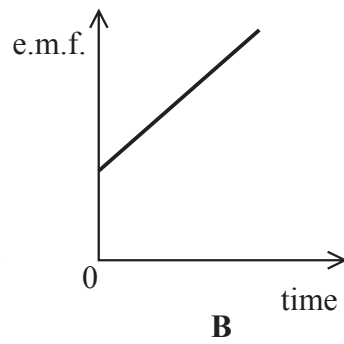
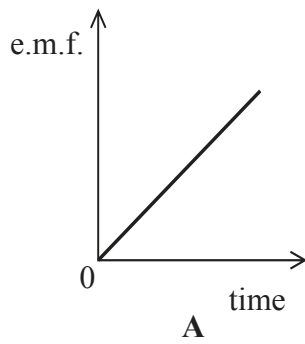

- A
- B
- C
- D

(Total for Question 8 = 1 mark)



Questions 9 and 10 refer to the diagram below.

The diagram shows the tracks in a particle detector. A lambda particle has decayed at O and two particles P and Q were created.

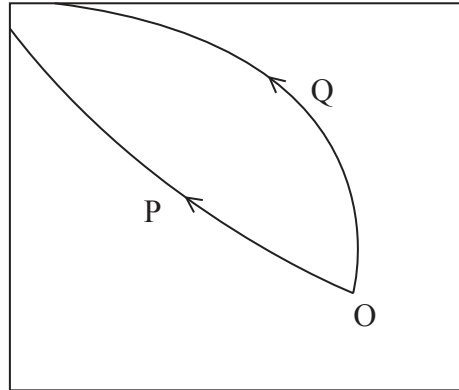

9 Which of the following is a correct statement about momentum in this decay?

- A The total momentum of the system is zero.
- B The momentum of P is equal to the momentum of Q.
- C The sum of the momenta of P and Q must equal zero.
- D The sum of the momenta of P and Q must equal that of the lambda particle.

(Total for Question 9 = 1 mark)

10 Which of the following must be a correct statement about energy in this decay?

- A total energy of P and Q < total energy of the lambda particle
- B total energy of P and Q = total energy of the lambda particle
- C total energy of P and Q > total energy of the lambda particle
- D total energy of P > total energy of Q

(Total for Question 10 = 1 mark)

TOTAL FOR SECTION A = 10 MARKS



SECTION B

Answer ALL questions in the spaces provided.

- 11 An alpha particle ${}^4_2\text{He}$ is travelling directly towards the nucleus of a gold atom ${}^{197}_{79}\text{Au}$. The graph shows how the force F between the particles varies with their separation r over a short distance.

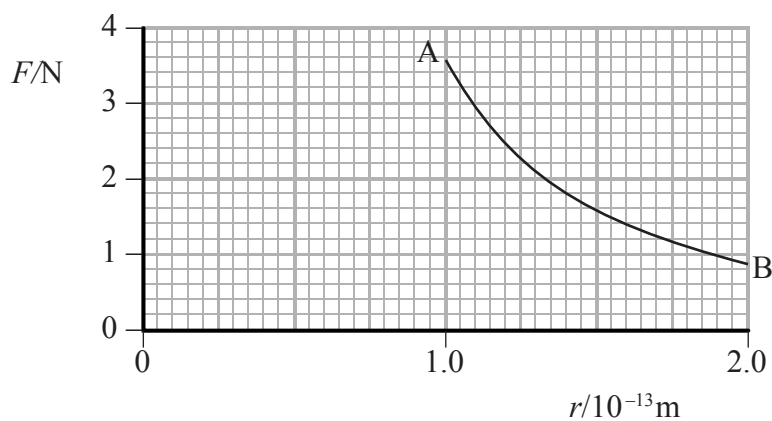

- (a) The relationship between F and r obeys an inverse square law. With reference to points A and B on the graph, explain what this means.

(2)

.....

.....

.....

.....

.....

- (b) Calculate the force between the alpha particle and the gold nucleus when their separation is at its minimum value of $4.5 \times 10^{-14} \text{ m}$.

(3)

.....

.....

.....

.....

.....

Force =

(Total for Question 11 = 5 marks)



12 A capacitor can be charged and discharged using the following circuit. It can be assumed that the ammeter has zero resistance.

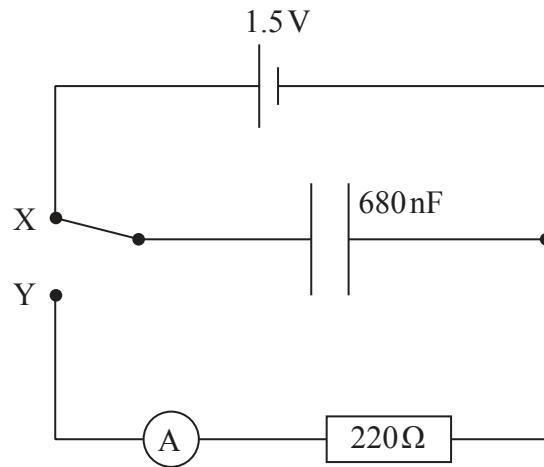

- (a) Initially the switch makes contact at X.
Calculate the charge stored by the capacitor when it is fully charged.

(2)

Charge =

- (b) The switch is moved to make contact at Y so that the fully charged capacitor is discharged through the $220\ \Omega$ resistor.

Calculate the charge remaining on the capacitor after it has been discharging for 1.0 ms and comment on your answer.

(4)

Charge =

Comment



(c) The capacitor is charged and discharged 500 times per second.

Calculate the average current through the ammeter.

(2)

.....

.....

.....

.....

Average current =

(Total for Question 12 = 8 marks)



13 (a) State the principle of conservation of momentum.

(2)

.....

.....

.....

(b) A head-on collision occurs between a neutron and a beryllium atom ${}^9_4\text{Be}$. The nucleus of the beryllium atom absorbs the neutron to form the isotope ${}^{10}_4\text{Be}$.

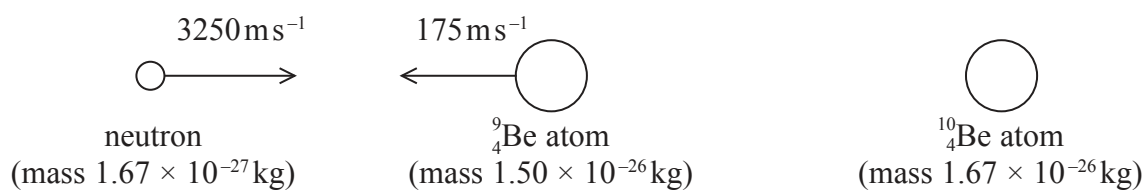

(i) Calculate the velocity of the ${}^{10}_4\text{Be}$ atom, indicating its direction by adding an arrow to the diagram.

(4)

.....

.....

.....

.....

.....

.....

.....

Velocity =

(ii) Using a suitable calculation, determine whether the collision was elastic or inelastic.

(2)

.....

.....

.....

.....

.....

.....

(Total for Question 13 = 8 marks)



BLANK PAGE



14 (a) State Faraday's law of electromagnetic induction.

(2)

.....

.....

.....

.....

(b) Vehicles such as buses may be powered by electric motors. The motors on these buses use batteries which need to be charged often. This is normally done by connecting to a fixed electrical supply whilst the bus is parked.

The photograph shows a bus on a road in South Korea. This road enables the batteries to charge whilst the bus is in motion.



Under the road there are electric cables, connected to a 440V 60 Hz supply. These generate magnetic fields. There is a coil inside the charging device which is located below the floor of the bus. This enables the batteries on the bus to charge.

*(i) Explain how this system works.

(3)

.....

.....

.....

.....

.....

.....

.....

.....

.....



- (ii) It is not necessary for the cable to be installed under the entire length of the road. The batteries used to power these buses can be much smaller than those used in other electric buses.

Explain why the cables do not need to be installed under the entire length of the road and why the batteries can be smaller.

(3)

.....

.....

.....

.....

.....

.....

.....

.....

.....

.....

(Total for Question 14 = 8 marks)



15 Hammer Throwing is an Olympic sport. The sport uses a metal sphere attached to a chain. The athlete holds the chain and spins around to give the sphere a large angular velocity.



When the sphere is released it travels in a parabolic path through the air and lands on the ground.

(a) Explain why, at the instant of release, the sphere stops travelling in a circular path. (2)

.....

.....

.....

.....

(b) The sphere has a mass of 7.3 kg. The athlete moves the sphere through a circle of radius 1.7 m. The speed of the sphere, at the instant of release, is 18 m s^{-1} .

(i) Calculate the angular velocity of the sphere. (2)

.....

.....

.....

Angular velocity =

(ii) Assuming that both the circle and chain are horizontal, calculate the force that the athlete exerts on the chain just before its release. (2)

.....

.....

.....

.....

Force =



16 A beam of identical positive ions travels horizontally in a vacuum. The ions pass between two charged plates and are deflected downwards by the electric field between the plates.

The diagram shows the path of one of the ions.

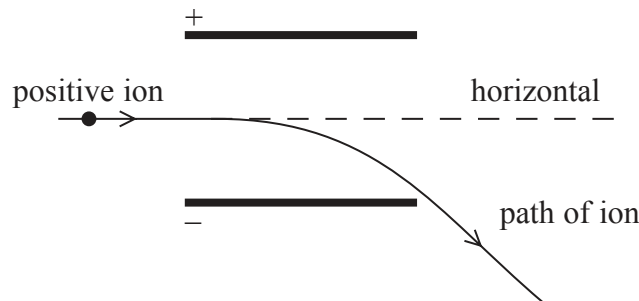

*(a) Explain the path of the ion both between the plates and when it has left the plates.

(4)

.....

.....

.....

.....

.....

.....

.....

.....

.....

.....

.....

(b) Whilst the electric field is still acting, the path of the ions can be returned to the horizontal by applying a magnetic field over the same region as the electric field acts.

(i) Explain the conditions under which the ions have no overall deflection as they pass between the plates.

(2)

.....

.....

.....

.....



(ii) The ions have a velocity of 260 km s^{-1} . The plate separation is 4.5 cm and the potential difference across the plates is 60 V .

Calculate the magnetic flux density required so that there is no overall deflection of the ions.

(4)

.....

.....

.....

.....

.....

.....

.....

.....

Magnetic flux density =

(c) State and explain how the path of the ions in just the magnetic field would be different from the path in just the electric field.

(3)

.....

.....

.....

.....

.....

.....

.....

.....

(Total for Question 16 = 13 marks)



17 (a) High energy particles used to investigate the structure of matter are produced in particle accelerators. The diagram shows the main features of a linear accelerator (linac).

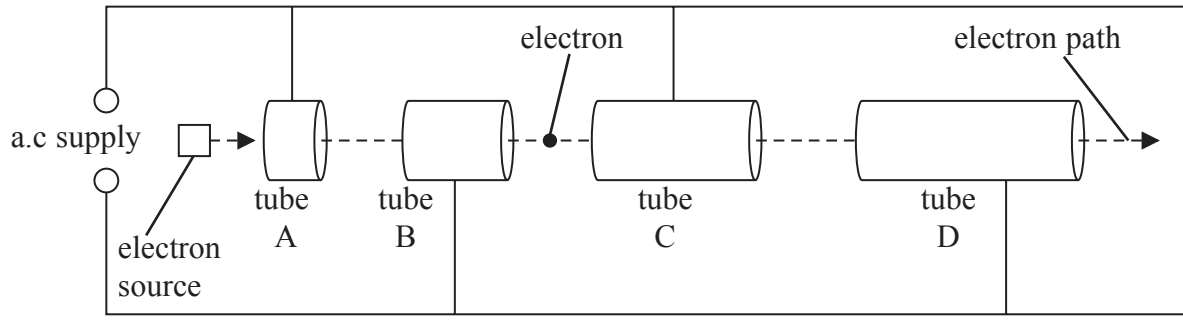

(i) An electron is shown between tubes B and C.

The circles on the diagram indicate the terminals of the a.c. supply. Indicate on the diagram their polarity when the electron is between tubes B and C.

Explain your answer.

(2)

.....

.....

.....

(ii) Explain why it is necessary for the tubes to increase in length along the linac.

(1)

.....

.....

(iii) The peak voltage of the a.c. supply is 250 kV.

Calculate the increase in electron kinetic energy, in joules, as the electron moves from tube A to tube D.

(3)

.....

.....

.....

.....

Increase in kinetic energy = J



(b) The Antiproton Decelerator at CERN slows down very high energy antiprotons to produce anti-atoms such as anti-hydrogen.

The diagram is a representation of a hydrogen atom and an anti-hydrogen atom.

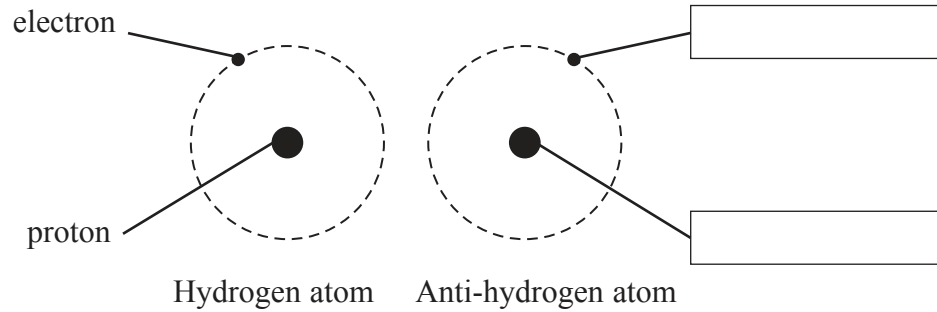

- (i) Use the boxes in the diagram to identify the particles in the anti-hydrogen atom. (1)
- (ii) State one difference and one similarity between the electron and its corresponding particle in the anti-hydrogen atom. (2)

.....

.....

.....

- (iii) State what would happen if a hydrogen atom collided with an anti-hydrogen atom. (1)

.....

.....



(c) In the early 1960s Murray Gell-Mann proposed a quark model that consisted of three quarks. The table gives some of the properties of these quarks.

Quark	Charge	Predicted mass in MeV/c ²
Up (u)	+2/3	4
Down (d)	-1/3	4
Strange (s)	-1/3	80

(i) Explain what is meant by a charge of +2/3.

(2)

.....

.....

.....

(ii) State the predicted mass and charge of the \bar{u} quark.

(2)

.....

.....

(iii) Calculate the mass of the \bar{s} quark in kg.

(3)

.....

.....

.....

.....

Mass = kg

(Total for Question 17 = 17 marks)

TOTAL FOR SECTION B = 70 MARKS

TOTAL FOR PAPER = 80 MARKS



List of data, formulae and relationships

Acceleration of free fall	$g = 9.81 \text{ m s}^{-2}$	(close to Earth's surface)
Boltzmann constant	$k = 1.38 \times 10^{-23} \text{ J K}^{-1}$	
Coulomb's law constant	$k = 1/4\pi\epsilon_0$ $= 8.99 \times 10^9 \text{ N m}^2 \text{ C}^{-2}$	
Electron charge	$e = -1.60 \times 10^{-19} \text{ C}$	
Electron mass	$m_e = 9.11 \times 10^{-31} \text{ kg}$	
Electronvolt	$1 \text{ eV} = 1.60 \times 10^{-19} \text{ J}$	
Gravitational constant	$G = 6.67 \times 10^{-11} \text{ N m}^2 \text{ kg}^{-2}$	
Gravitational field strength	$g = 9.81 \text{ N kg}^{-1}$	(close to Earth's surface)
Permittivity of free space	$\epsilon_0 = 8.85 \times 10^{-12} \text{ F m}^{-1}$	
Planck constant	$h = 6.63 \times 10^{-34} \text{ J s}$	
Proton mass	$m_p = 1.67 \times 10^{-27} \text{ kg}$	
Speed of light in a vacuum	$c = 3.00 \times 10^8 \text{ m s}^{-1}$	
Stefan-Boltzmann constant	$\sigma = 5.67 \times 10^{-8} \text{ W m}^{-2} \text{ K}^{-4}$	
Unified atomic mass unit	$u = 1.66 \times 10^{-27} \text{ kg}$	

Unit 1

Mechanics

Kinematic equations of motion	$v = u + at$ $s = ut + \frac{1}{2}at^2$ $v^2 = u^2 + 2as$
Forces	$\Sigma F = ma$ $g = F/m$ $W = mg$
Work and energy	$\Delta W = F\Delta s$ $E_k = \frac{1}{2}mv^2$ $\Delta E_{\text{grav}} = mg\Delta h$

Materials

Stokes' law	$F = 6\pi\eta rv$
Hooke's law	$F = k\Delta x$
Density	$\rho = m/V$
Pressure	$p = F/A$
Young modulus	$E = \sigma/\epsilon$ where Stress $\sigma = F/A$ Strain $\epsilon = \Delta x/x$
Elastic strain energy	$E_{\text{el}} = \frac{1}{2}F\Delta x$



P 4 4 9 2 7 A 0 2 1 2 4

Unit 2

Waves

Wave speed	$v = f\lambda$
Refractive index	${}_1\mu_2 = \sin i / \sin r = v_1 / v_2$

Electricity

Potential difference	$V = W/Q$
----------------------	-----------

Resistance	$R = V/I$
------------	-----------

Electrical power, energy and efficiency	$P = VI$ $P = I^2R$ $P = V^2/R$ $W = VIt$
---	--

$$\% \text{ efficiency} = \frac{\text{useful energy output}}{\text{total energy input}} \times 100$$

$$\% \text{ efficiency} = \frac{\text{useful power output}}{\text{total power input}} \times 100$$

Resistivity	$R = \rho l/A$
-------------	----------------

Current	$I = \Delta Q / \Delta t$ $I = nqvA$
---------	---

Resistors in series	$R = R_1 + R_2 + R_3$
---------------------	-----------------------

Resistors in parallel	$\frac{1}{R} = \frac{1}{R_1} + \frac{1}{R_2} + \frac{1}{R_3}$
-----------------------	---

Quantum physics

Photon model	$E = hf$
--------------	----------

Einstein's photoelectric equation	$hf = \phi + \frac{1}{2}mv_{\max}^2$
-----------------------------------	--------------------------------------



Unit 4

Mechanics

Momentum	$p = mv$
Kinetic energy of a non-relativistic particle	$E_k = p^2/2m$
Motion in a circle	$v = \omega r$ $T = 2\pi/\omega$ $F = ma = mv^2/r$ $a = v^2/r$ $a = r\omega^2$

Fields

Coulomb's law	$F = kQ_1Q_2/r^2$ where $k = 1/4\pi\epsilon_0$
Electric field	$E = F/Q$ $E = kQ/r^2$ $E = V/d$
Capacitance	$C = Q/V$
Energy stored in capacitor	$W = \frac{1}{2}QV$
Capacitor discharge	$Q = Q_0e^{-t/RC}$
In a magnetic field	$F = BIl \sin \theta$ $F = Bqv \sin \theta$ $r = p/BQ$
Faraday's and Lenz's Laws	$\epsilon = -d(N\phi)/dt$

Particle physics

Mass-energy	$\Delta E = c^2 \Delta m$
de Broglie wavelength	$\lambda = h/p$





BLANK PAGE

